

# O-TOK3040-T

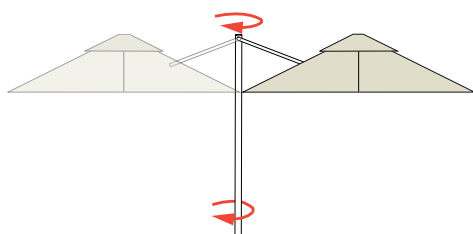

MADE IN ITALY

ROTAZIONE 360°



Ombrellone made in Italy a palo laterale in legno con telo rettangolare 3x4metri.

Palo	Legno IROKO - 92x92 mm
Braccio	Legno IROKO - 72x72 mm
Stecche	Intercambiabili legno KOTÒ - 17x35 mm
Treatmento legno	Vernici ad acqua
Telo*	- 100% acrilico 300 gr - acrilico resinato 390 gr
Balza	Disponibile con o senza balza
Apertura-Chiusura	Carrucola e arganello con manovella
Basamenti	Piastra in acciaio per il fissaggio a terra

\* Gli ombrelloni Danieli si distinguono per la qualità della lavorazione artigianale e dei materiali scelti. Utilizziamo solo tessuti composti da fibra acrilica per garantire solidità alla luce, permeabilità all'aria. Trattato con resine fluorocarboniche che garantiscono: la protezione antimacchia, l'idrorepellenza, la traspirabilità.

La costruzione del tessuto 100% acrilico prevede una trama da 14 fili/cm ca. per un peso di 300 g/mq.

Per il tessuto acrilico resinato, caratterizzato da spalmatura con resine acriliche, è prevista una trama da 17fili/cm e il peso è di 390 gr/mq.

## COLORE TELO ACRILICO RESINATO



ecrù

## COLORI TELO 100% ACRILICO



ecrù



corda



giallo



testa di moro



tortora



bordeaux



verde foresta



nero



antracite

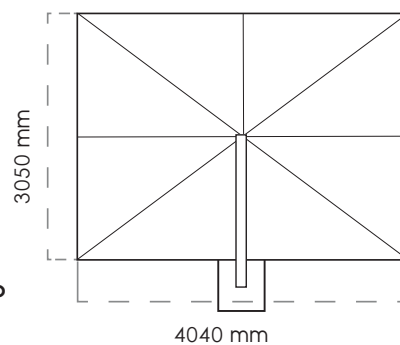
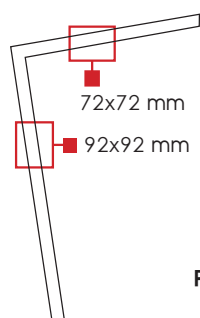
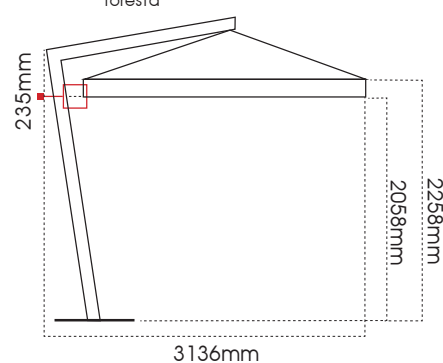
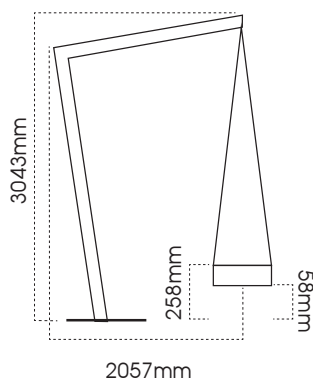

## Piastra per ancoraggio

